



Pump & Motor Division

Dump Pump Series – G, SG, C



ENGINEERING YOUR SUCCESS.



WARNING — User Responsibility

FAILURE OR IMPROPER SELECTION OR IMPROPER USE OF THE PRODUCTS AND/OR SYSTEMS DESCRIBED HEREIN OR RELATED ITEMS CAN CAUSE DEATH, PERSONAL INJURY AND PROPERTY DAMAGE.

This document and other information from Parker Hannifin Corporation, its subsidiaries and authorized distributors provide product and/or system options for further investigation by users having technical expertise. It is important that you analyze all aspects of your application and review the information concerning the product or system in the current product catalog. Due to the variety of operating conditions and applications for these products or systems, the user, through its own analysis and testing, is solely responsible for making the the products and systems and assuring that all performance, safety and warning requirements of the application are met.

The products described herein, including without limitation, product features, specifications, designs, availability and pricing, are subject to change by Parker Hannifin Corporation and its subsidiaries at any time without notice.

Offer of Sale

The items described in this document are hereby offered for sale by Parker Hannifin Corporation, its subsidiaries or its authorized distributors. This offer and its acceptance are governed by the provisions stated in the "Offer of Sale".

© Copyright 2021, Parker Hannifin Corporation, All Rights Reserved



WARNING: This product can expose you to chemicals including lead or DEHP which are known to the state of California to cause cancer, birth defects, and other reproductive harm. www.p65warnings.ca.gov

Table of Contents

Characteristics	1-2
Specifications	3
Dimensions	4-6
G101/G102.....	4
SG102.....	5
C101/C102.....	6
Performance Data/Charts	7-9
G101/G102.....	7
SG102.....	8
C101/C102.....	9
Flow Paths	10-11
Air Shift Kits	12
Ordering Code	13
Offer of Sale	15-16

 **WARNING:** This product can expose you to chemicals including lead or DEHP which are known to the state of California to cause cancer, birth defects, and other reproductive harm. www.p65warnings.ca.gov

G

- Original Commercial dump pump design
- Durable high-strength cast iron body for excellent power to weight ratio
- Cast Iron construction for durability
- Balanced thrust plates minimize friction and leakage
- Roller bearings for durability and resistance to fluid contamination
- More compact design allowing for easier fitment

**SG**

- 25% greater flow than G102 2" dump pump
- 20% less weight than the C102 2.5" dump pump
- Large pump valve body flow characteristics
- 4-bolt B or 4-bolt DIN flange
- 13T B or 8T DIN shaft
- Pressures to 172 bar (2500 PSI)
- Manual or air shift option

**C**

- Original Commercial dump pump design
- Durable high-strength cast iron body for excellent power to weight ratio
- Cast Iron construction for durability
- Balanced thrust plates minimize friction and leakage
- Roller bearings for durability and resistance to fluid contamination

**The Broadest Choice**

We sell more pump/valve combinations for dump trucks and trailers than any other manufacturer for two reasons: our pump/valve family offer the broadest choice of flow ratings; these units provide the most reliable, trouble-free control for dump trucks.

Underbody Hoist to Big Trailers – We Have Your Pump

Our dump body pump/valve products deliver the right flow range for most applications at 1800 RPM / 2000 PSI. Models with two shafts (C101/G101) can be mounted to remote PTO's operating in either direction of rotation. Single shaft units (G102/SG102/C102) mount directly to the vehicle drive train. All can be connected in two- or three-line circuits to control single-acting cylinders.

All units are supplied with factory-set 2000 PSI relief valves, and also includes the 3-line sleeve.

⚠ WARNING: This product can expose you to chemicals including lead or DEHP which are known to the state of California to cause cancer, birth defects, and other reproductive harm. www.p65warnings.ca.gov

G

Product Features	Description
Pump Type	Fixed
Installation	2- or 3-line installations
Speed	Up to 2400 RPM

Product Features	Description
Theoretical Displ.	29 GPM @ 1800 RPM
Outlet Pressure	Up to 2500 PSI
Mountings	4-Bolt B / DIN / Remote

SG

Product Features	Description
Pump Type	Fixed
Installation	2- or 3-line installations
Speed	Up to 2400 RPM

Product Features	Description
Theoretical Displ.	38 GPM @ 1800 RPM
Outlet Pressure	Up to 2500 PSI
Mountings	4-Bolt B / DIN

C

Product Features	Description
Pump Type	Fixed
Installation	2- or 3-line installations
Speed	Up to 2400 RPM

Product Features	Description
Theoretical Displ.	48 GPM @ 1800 RPM
Outlet Pressure	Up to 2500 PSI
Mountings	4-Bolt B / Remote

NOTE: Different types of pump options are available in terms of shaft, mounting and port type. Please contact Parker.

Performance data shown are average results based on a series of production units and are not representative of any one unit. Tests were run with the oil reservoir temperature at 120°F, viscosity of 150 SUS at 100°F. Requests for more specific data should be directed to our Product Support Department through your sales representative or GPDtechservice@parker.com.

 **WARNING:** This product can expose you to chemicals including lead or DEHP which are known to the state of California to cause cancer, birth defects, and other reproductive harm. www.p65warnings.ca.gov

G

G101/G102 Frame Size	20
Displacement – cm ³ /rev (in ³ /rev)	64.6 (3.9)
Max continuous pressure – bar (psi)	172 (2,500)
Max Speed – RPM	2,400
Approximate Weight – Lbs. [kg]	43 [19.5]

SG

SG102 Frame Size	25
Displacement – cm ³ /rev (in ³ /rev)	80.8 (4.93)
Max continuous pressure – bar (psi)	172 (2,500)
Max Speed – RPM	2,400
Approximate Weight – Lbs. [kg]	56 [25.4]

C

C101/C102 Frame Size	25
Displacement – cm ³ /rev (in ³ /rev)	104.5 (6.40)
Max continuous pressure – bar (psi)	172 (2,500)
Max Speed – RPM	2,400
Approximate Weight – Lbs. [kg]	71 [32.2]

 **WARNING:** This product can expose you to chemicals including lead or DEHP which are known to the state of California to cause cancer, birth defects, and other reproductive harm. www.p65warnings.ca.gov

G101/G102

G101

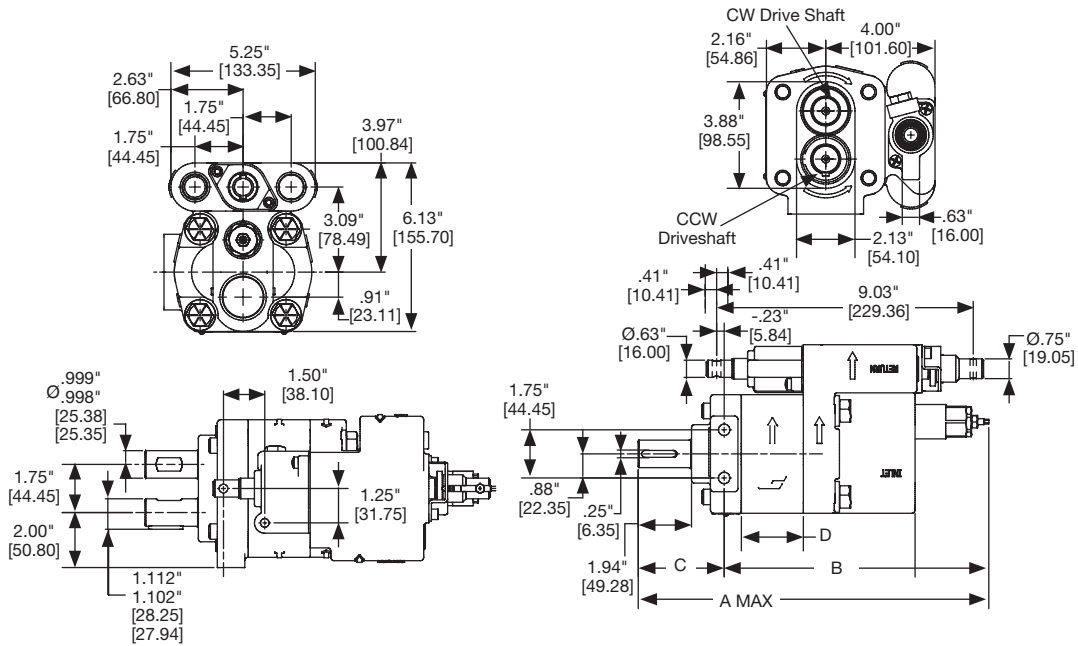

G102 (CW Rotation Shown)

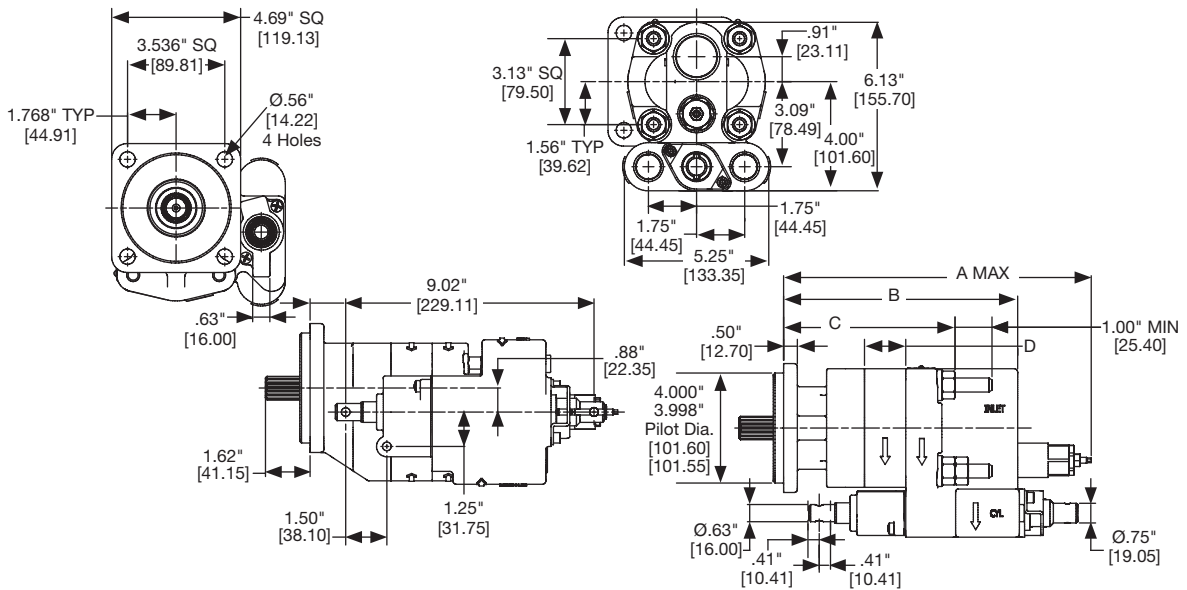

Gear Width	Series	G101/G102 Dimensions				SHIPPING WEIGHTS (Approx.)	
		A	B	C	D	lbs.	kgs.
2.00"	G102	12.50" [317.50]	9.75" [247.70]	7.50" [190.50]	2.75" [69.80]	42	19.05
	G101	13.19" [335.00]	7.44" [189.00]	3.12" [79.30]	2.75" [69.80]	38	17.24

WARNING: This product can expose you to chemicals including lead or DEHP which are known to the state of California to cause cancer, birth defects, and other reproductive harm. www.p65warnings.ca.gov

SG102

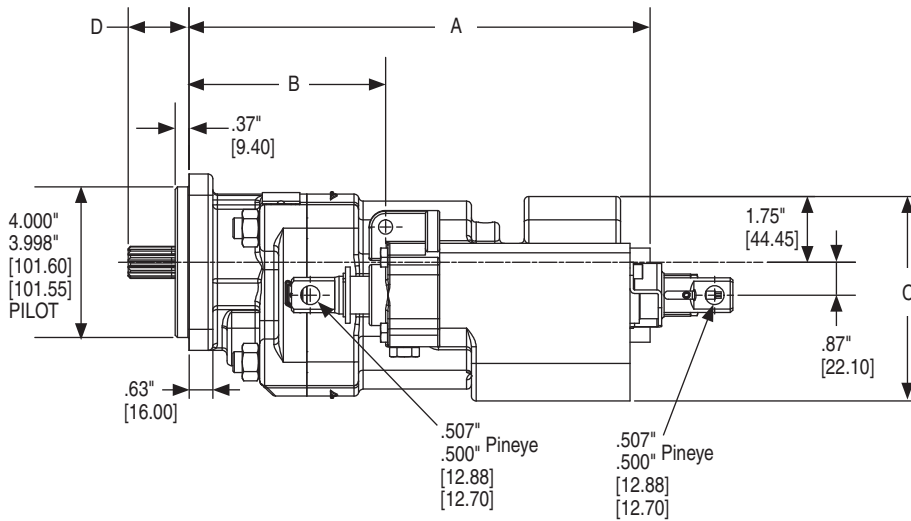
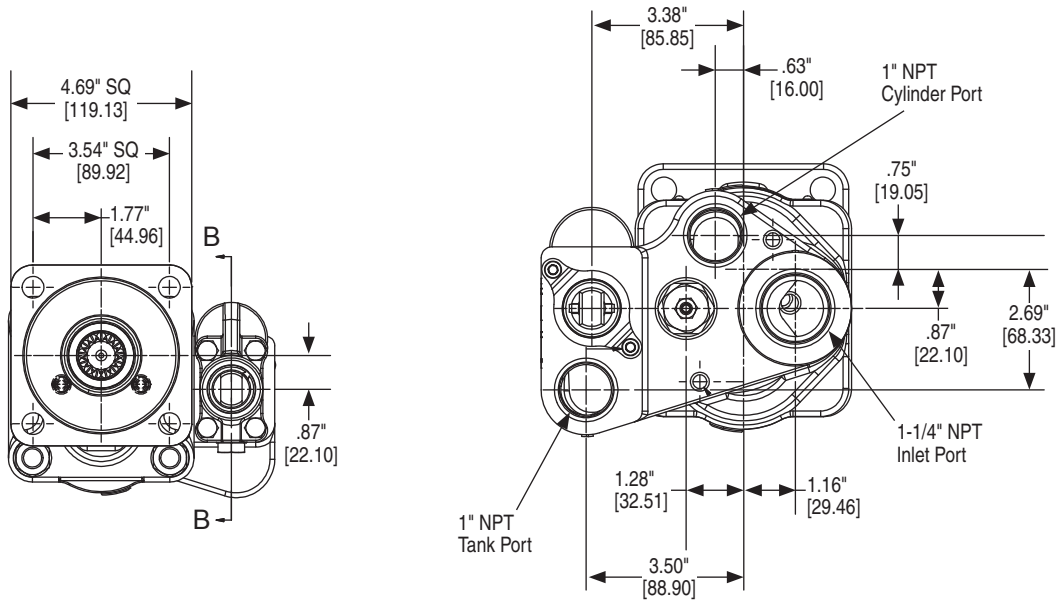

Gear Width	SG102 Dimensions				SHIPPING WEIGHTS (Approx.)	
	A	B	C	D	lbs.	kgs.
2.50"	12.26" [311.40]	5.22" [132.59]	5.44" [138.18]	1.62" [119.13]	56	25.40

WARNING: This product can expose you to chemicals including lead or DEHP which are known to the state of California to cause cancer, birth defects, and other reproductive harm. www.p65warnings.ca.gov

C101/C102

C101

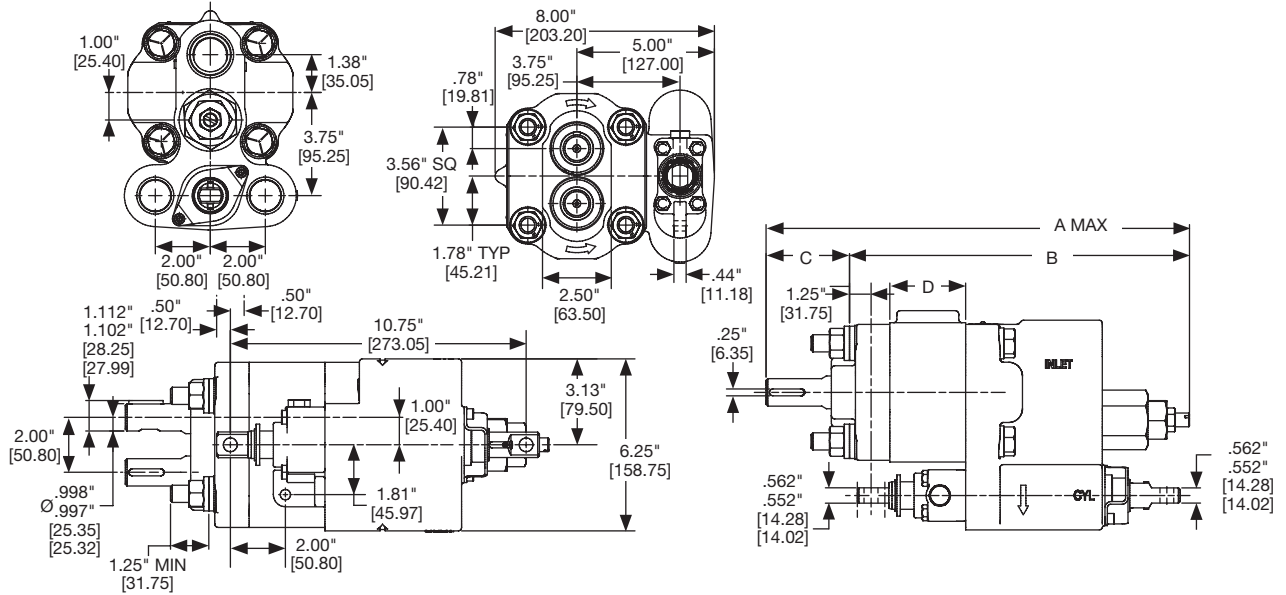

C102 (CCW Rotation Shown)

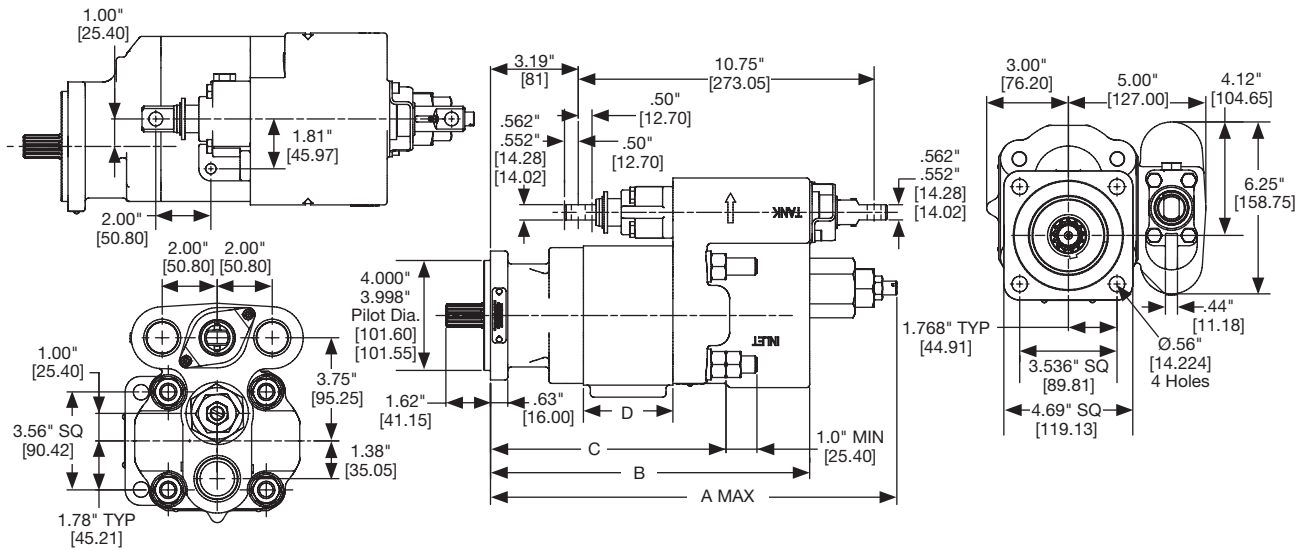

Gear Width	Series	C101/C102 Dimensions				SHIPPING WEIGHTS (Approx.)	
		A	B	C	D	lbs.	kgs.
2.50"	C102	15.00" [381.00]	11.59" [294.40]	8.58" [217.9]	3.25" [82.55]	70	31.75
	C101	16.13" [409.70]	13.10" [332.23]	3.03" [76.96]	3.25" [82.55]	67	30.39

WARNING: This product can expose you to chemicals including lead or DEHP which are known to the state of California to cause cancer, birth defects, and other reproductive harm. www.p65warnings.ca.gov

G, SG, C RPM, Weight, GPM

Series		G101/G102	SG102	C101/C102
Gear Width		20	25	25
Actual Displacement	cc	64.6	80.8	104.5
	cir	3.94	4.93	6.38
Speed (RPM)	min	500	500	500
	max	2400	2400	2400
Weight*	lbs	43	56	71
	kg	19.5	25.4	32.2

* All weights are approximate. The actual weight of an assembly will depend upon the porting and the type of flange and shaft specified.

Pump Performance G101/G102

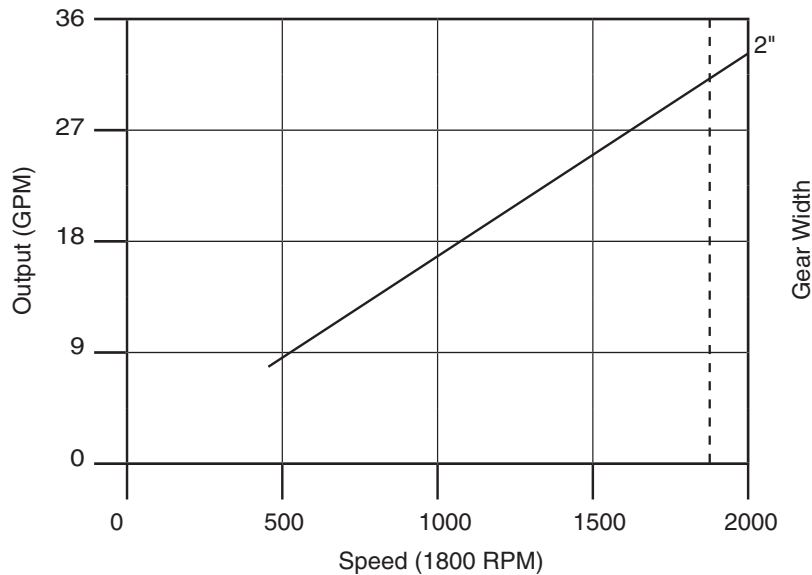

Model Number	Maximum PSI	GPM @ 1800 RPM	Maximum Speed
		2"	
G101/G102	2500	29	2400 RPM

* All G102 units can be ordered for either direction of rotation from the factory.

WARNING: This product can expose you to chemicals including lead or DEHP which are known to the state of California to cause cancer, birth defects, and other reproductive harm. www.p65warnings.ca.gov

Pump Performance SG102

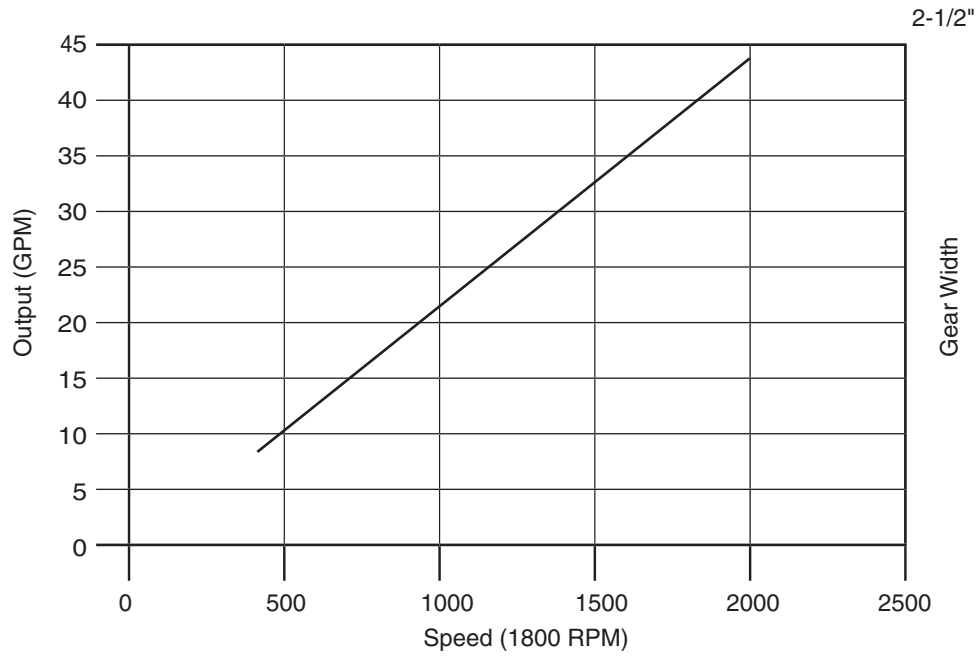

Model Number	Maximum PSI	GPM @ 1800 RPM	Maximum Speed
		2-1/2"	
SG102	2500	38.4	2400 RPM

* All SG102 units can be ordered for either direction of rotation from the factory.

WARNING: This product can expose you to chemicals including lead or DEHP which are known to the state of California to cause cancer, birth defects, and other reproductive harm. www.p65warnings.ca.gov

Pump Performance C101/C102

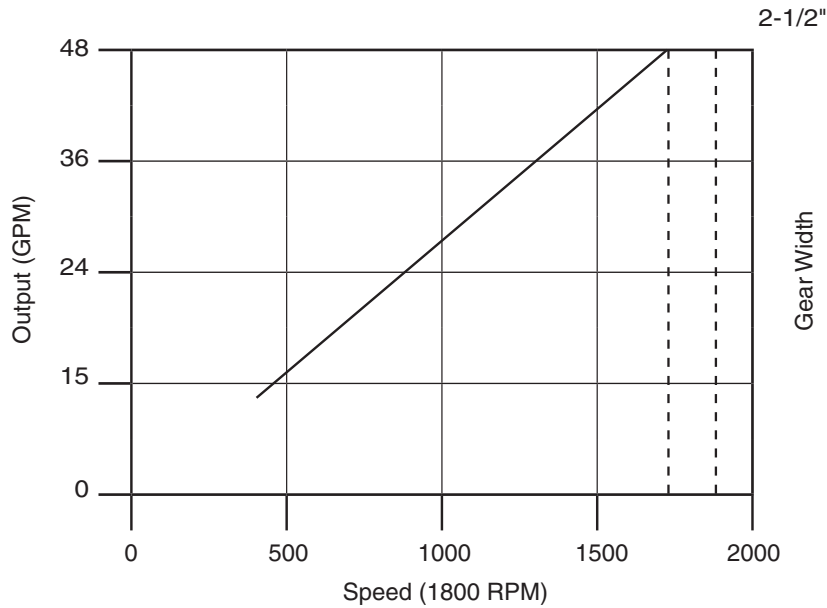

Model Number	Maximum PSI	GPM @ 1800 RPM	Maximum Speed
		2-1/2"	
C101/C102	2500	48	2400 RPM

* All C102 units can be ordered for either direction of rotation from the factory.

WARNING: This product can expose you to chemicals including lead or DEHP which are known to the state of California to cause cancer, birth defects, and other reproductive harm. www.p65warnings.ca.gov

Pump/Valve Units: Explanation of single-acting valve.

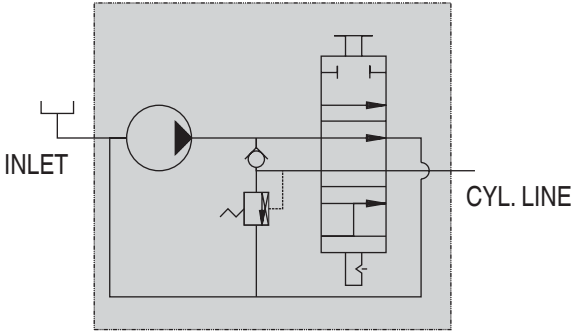
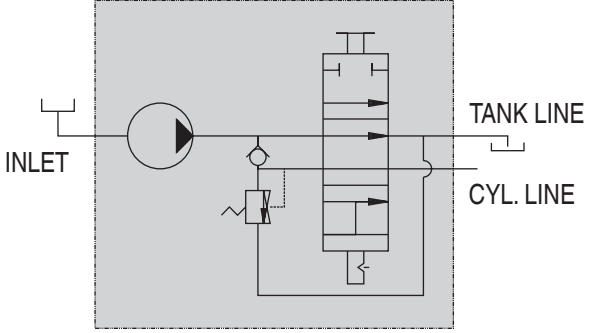
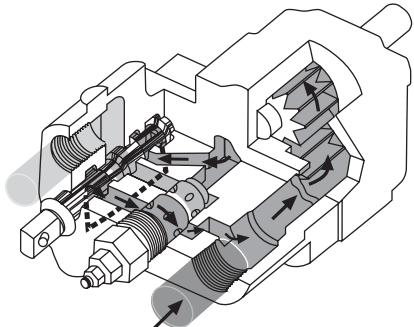
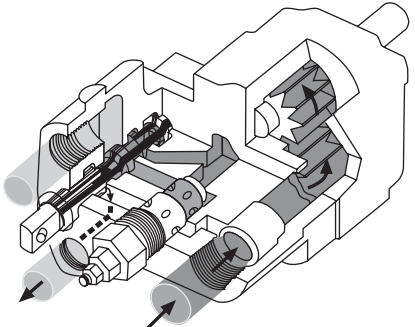
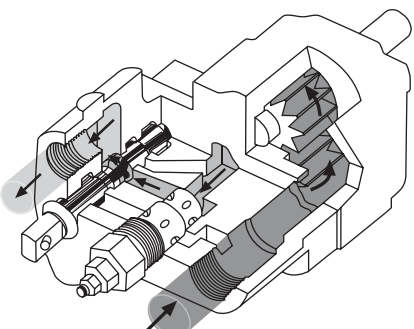
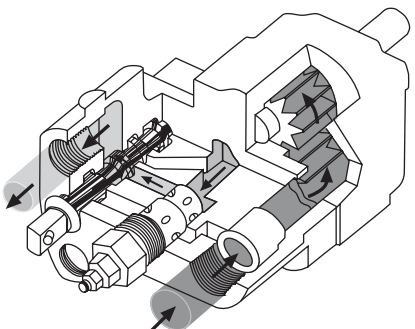
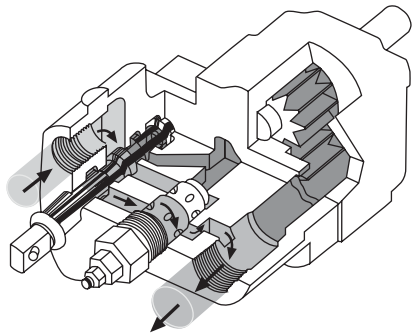
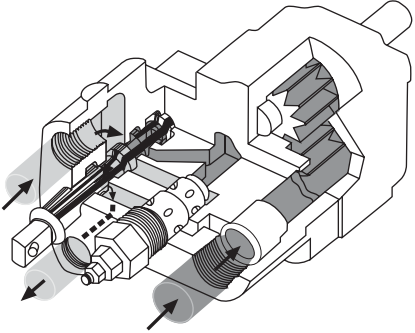
<p>2-Line</p>	<p>Installation: One line to the cylinder, one line to the reservoir. For intermittent operation.</p> 	<p>3-Line</p>	<p>Installation: One line to the cylinder, two lines to the reservoir. For continuous or intermittent operation.</p> 
<p>2-Line</p>	<p>Spool in Neutral: Oil recirculates internally.</p> 	<p>3-Line</p>	<p>Spool in Neutral: Oil circulates through the pump and returns to tank.</p> 
<p>2-Line</p>	<p>Raise Position: Oil is routed through work port to raise the cylinder.</p> 	<p>3-Line</p>	<p>Raise Position: Oil is routed through work port to raise the cylinder.</p> 
<p>2-Line</p>	<p>Lower Position: Oil flows from the cylinder through the relief valve to return to tank.</p> 	<p>3-Line</p>	<p>Lower Position: Oil flows from the cylinder, through the bottom port and returns to tank.</p> 

Continued on Next Page

WARNING: This product can expose you to chemicals including lead or DEHP which are known to the state of California to cause cancer, birth defects, and other reproductive harm. www.p65warnings.ca.gov

Warning: These warnings apply to all pump/valve units.

- **A device to lock the control lever in the neutral position must be installed. Pump/valve units without a lockable control lever may allow the dump bed to rise unintentionally while in transit. Failure to provide such a lock may lead to loss of vehicle control, accidental injury and/ or property damage.**
- **Failure to disengage the PTO from driving the pump/valve when in transit may allow the dump bed to rise unintentionally. This may lead to loss of vehicle control, accidental injury and/or property damage.**
- The pump/valves are equipped with a neutral stop device for those applications using a pull-out cable. This device allows the pull-out cable to move the valve spool from the raise to the neutral position only. Since shock loading in the cable is possible, **it is essential that a spring (Part no. 391-3581-854 or equal) be incorporated in the pull-out cable hookup.** Failure to do so could result in breakage of the neutral stop device and could lead to injury. We recommend that the cable be fully enclosed and directly in line with the spool.

- **Never work under a raised dump bed without first securely blocking the bed to prevent its accidental lowering.**

- Three-line installations are recommended whenever possible. Three-line circuits consist of a pump inlet line, a line to the cylinder and a return line to tank. A sleeve must be installed in the pump's inlet to allow oil to circulate through the unit and return to tank when running in neutral. Lower operating temperatures and the ability to install a return-line filter are two advantages of a three-line circuit. Be sure the return line is always below the oil level in the reservoir.

Two-line installations are for intermittent operation only

If you do not understand these warnings or have any questions about any of them, contact your distributor or the Product Support Group at: Phone (330) 746-8011 or Fax (330) 740-8344.

 **WARNING:** This product can expose you to chemicals including lead or DEHP which are known to the state of California to cause cancer, birth defects, and other reproductive harm. www.p65warnings.ca.gov

All dump units can be shifted from the cab by cable or by air with our Air Shift kit.

The kit consists of an air cylinder that mounts on the valve unit, a pneumatic control valve that mounts in the cab, 30' of air hose and all necessary connections. A minimum of 80 PSI air pressure is required, which can be taken off the brake system or on-board compressor. The shifter can be retro-fit easily to existing pump/valve units by following the simple instructions with each kit.

C101/C102 Air Shift Kits	10 Digit Part No.
ASK-6 without Toggle with Air Hose, Fittings.....	314-9414-006
ASK-17 without Air Hose, Fittings	314-9414-017

SG102 Air Shift Kits	10 Digit Part No.
ASK-16 without Toggle with Air Hose, Fittings.....	314-9414-006
ASK-17 without Air Hose, Fittings	314-9414-017

G101/G102 Air Shift Kits	10 Digit Part No.
ASK-16 without Toggle with Air Hose, Fittings.....	308-9414-016
ASK-49 without Air Valve, Hose, Fittings	308-9414-049

 **WARNING:** This product can expose you to chemicals including lead or DEHP which are known to the state of California to cause cancer, birth defects, and other reproductive harm. www.p65warnings.ca.gov

G101/G102

G	1	0	2	3	4	5	6	7	8
---	---	---	---	---	---	---	---	---	---

2 – Mounting	
1	Remote Mount
2	Direct Mount

4, 5 – Displacements		
2.0	2.0	3.9 in ³ /rev

7, 8 – Mounting Flange	
4S	SAE B 4-Bolt
4D	DIN 4-Bolt

3 – Spool Options	
1	Detent

6 – Rotation	
R	Clockwise
L	Counter Clockwise

SG102

S	G	1	0	2	3	4	5	6	7	8
---	---	---	---	---	---	---	---	---	---	---

2 – Mounting	
2	Direct Mount

4, 5 – Displacements		
2.5	2.5	4.93 in ³ /rev

7, 8 – Mounting Flange	
4S	SAE B 4-Bolt
4D	DIN 4-Bolt

3 – Spool Options	
1	Detent

6 – Rotation	
R	Clockwise
L	Counter Clockwise

C101/C102

C	1	0	2	D	3	4	5
---	---	---	---	---	---	---	---

2 – Mounting	
1	Remote Mount
2	Direct Mount

3, 4 – Displacements		
2.5	2.5	6.4 in ³ /rev

5 – Rotation	
Blank	Clockwise
1	Counter Clockwise

 **WARNING:** This product can expose you to chemicals including lead or DEHP which are known to the state of California to cause cancer, birth defects, and other reproductive harm. www.p65warnings.ca.gov

PARKER-HANNIFIN CORPORATION
OFFER OF SALE

1. Definitions. As used herein, the following terms have the meanings indicated.

"Buyer" means any customer receiving a Quote for Products.

"Buyer's Property" means any tools, patterns, plans, drawings, designs, specifications materials, equipment, or information furnished by Buyer, or which are or become Buyer's property.

"Confidential Information" means any technical, commercial, or other proprietary information of Seller, including, without limitation, pricing, technical drawings or prints and/or part lists, which has been or will be disclosed, delivered, or made available, whether directly or indirectly, to Buyer.

"Goods" means any tangible part, system or component to be supplied by Seller.

"Intellectual Property Rights" means any patents, trademarks, copyrights, trade dress, trade secrets or similar rights.

"Products" means the Goods, Services and/or Software as described in a Quote.

"Quote" means the offer or proposal made by Seller to Buyer for the supply of Products.

"Seller" means Parker-Hannifin Corporation, including all divisions, subsidiaries and businesses selling Products under these Terms.

"Seller's IP" means patents, trademarks, copyrights, or other intellectual property rights relating to the Products, including without limitation, names, designs, images, drawings, models, software, templates, information, any improvements or creations or other intellectual property developed prior to or during the relationship contemplated herein.

"Services" means any services to be provided by Seller.

"Software" means any software related to the Goods, whether embedded or separately downloaded.

"Special Tooling" means equipment acquired by Seller or otherwise owned by Seller necessary to manufacture Goods, including but not limited to tools, jigs, and fixtures.

"Terms" means the terms and conditions of this Offer of Sale.

2. Terms. All sales of Products by Seller will be governed by, and are expressly conditioned upon Buyer's assent to, these Terms. These Terms are incorporated into any Quote provided by Seller to Buyer. Buyer's order for any Products whether communicated to Seller verbally, in writing, by electronic data interface or other electronic commerce, shall constitute acceptance of these Terms. Seller objects to any contrary or additional terms or conditions of Buyer. Reference in Seller's order acknowledgement to Buyer's purchase order or purchase order number shall in no way constitute an acceptance of any of Buyer's terms or conditions of purchase. Any Quote made by Seller to Buyer shall be considered a firm and definite offer and shall not be deemed to be otherwise despite any language on the face of the Quote. Seller reserves all rights to accept or reject any purported acceptance by Buyer to Seller's Quote if such purported acceptance attempts to vary the terms of the Quote. If Seller ships Products after Buyer issues an acceptance to the Quote, any additional or different terms proposed by Buyer will not become part of the parties' business relationship unless agreed to in a writing that is signed by an authorized representative of Seller, excluding email correspondence. If the transaction proceeds without such agreement on the part of Seller, the business relationship will be governed solely by these Terms and the specific terms in Seller's Quote.

3. Price; Payment. The Products set forth in the Quote are offered for sale at the prices indicated in the Quote. Unless otherwise specifically stated in the Quote, prices are valid for thirty (30) days and do not include any sales, use, or other taxes or duties. Seller reserves the right to modify prices for any reason and at any time by giving ten (10) days prior written notice. Unless otherwise specified by Seller, all prices are F.C.A. Seller's facility (INCOTERMS 2020). All sales are contingent upon credit approval and full payment for all purchases is due thirty (30) days from the date of invoice (or such date as may be specified in the Quote). Under any circumstances, Buyer may not withhold or suspend payment of any amounts due and payable as a deduction, set-off or recoupment of any amount, claim or dispute with Seller. Unpaid invoices beyond the specified payment date incur interest at the rate of 1.5% per month or the maximum allowable rate under applicable law. Seller reserves the right to require advance payment or provision of securities for first and subsequent deliveries if there is any doubt, in Seller's sole determination, regarding the Buyer's creditworthiness or for other business reasons. If the requested advance payment or securities are not provided to Seller's satisfaction, Seller reserves the right to suspend performance or reject the purchase order, in whole or in part, without prejudice to Seller's other rights or remedies, including the right to full compensation. Seller may revoke or shorten any payment periods previously granted in Seller's sole determination. The rights and remedies herein reserved to Seller are cumulative and in

addition to any other or further rights and remedies available at law or in equity. No waiver by Seller of any breach by Buyer of any provision of these terms will constitute a waiver by Seller of any other breach of such provision.

4. Shipment; Delivery; Title and Risk of Loss. All delivery dates are approximate, and Seller is not responsible for damages or additional costs resulting from any delay. All deliveries are subject to our ability to procure materials from our suppliers. Regardless of the manner of shipment, delivery occurs and title and risk of loss or damage pass to Buyer, upon placement of the Products with the carrier at Seller's facility. Unless otherwise agreed prior to shipment and for domestic delivery locations only, Seller will select and arrange, at Buyer's sole expense, the carrier and means of delivery. When Seller selects and arranges the carrier and means of delivery, freight and insurance costs for shipment to the designated delivery location will be prepaid by Seller and added as a separate line item to the invoice. Buyer shall be responsible for any additional shipping charges incurred by Seller due to Buyer's acts or omissions. Buyer shall not return or repackage any Products without the prior written authorization from Seller, and any return shall be at the sole cost and expense of Buyer.

5. Warranty. The warranty for the Products is as follows:

(i) Goods are warranted against defects in material or workmanship for a period of twelve (12) months from the date of delivery or 2,000 hours of use, whichever occurs first; (ii) Services shall be performed in accordance with generally accepted practices and using the degree of care and skill that is ordinarily exercised and customary in the field to which the Services pertain and are warranted for a period of six (6) months from the date of completion of the Services; and (iii) Software is only warranted to perform in accordance with applicable specifications provided by Seller to Buyer for ninety (90) days from the date of delivery or, when downloaded by a Buyer or end-user, from the date of the initial download. All prices are based upon the exclusive limited warranty stated above, and upon the following disclaimer: **EXEMPTION CLAUSE; DISCLAIMER OF WARRANTY, CONDITIONS, REPRESENTATIONS: THIS WARRANTY IS THE SOLE AND ENTIRE WARRANTY, CONDITION, AND REPRESENTATION, PERTAINING TO PRODUCTS. SELLER DISCLAIMS ALL OTHER WARRANTIES, CONDITIONS, AND REPRESENTATIONS, WHETHER STATUTORY, EXPRESS OR IMPLIED, INCLUDING BUT NOT LIMITED TO THOSE RELATING TO DESIGN, NONINFRINGEMENT, MERCHANTABILITY, AND FITNESS FOR A PARTICULAR PURPOSE. SELLER DOES NOT WARRANT THAT THE SOFTWARE IS ERROR-FREE OR FAULT-TOLERANT, OR THAT BUYER'S USE THEREOF WILL BE SECURE OR UNINTERRUPTED, UNLESS OTHERWISE AUTHORIZED IN WRITING BY SELLER, THE SOFTWARE SHALL NOT BE USED IN CONNECTION WITH HAZARDOUS OR HIGH-RISK ACTIVITIES OR ENVIRONMENTS. EXCEPT AS EXPRESSLY STATED HEREIN, ALL PRODUCTS ARE PROVIDED "AS IS"**.

6. Claims; Commencement of Actions. Buyer shall promptly inspect all Products upon receipt. No claims for shortages will be allowed unless reported to Seller within ten (10) days of delivery. Buyer shall notify Seller of any alleged breach of warranty within thirty (30) days after the date the non-conformance is or should have been discovered by Buyer. Any claim or action against Seller based upon breach of contract or any other theory, including tort, negligence, or otherwise must be commenced within twelve (12) months from the date of the alleged breach or other alleged event, without regard to the date of discovery.

7. LIMITATION OF LIABILITY. IN THE EVENT OF A BREACH OF WARRANTY, SELLER WILL, AT ITS OPTION, REPAIR OR REPLACE THE NON-CONFORMING PRODUCTS, RE-PERFORM THE SERVICES, OR REFUND THE PURCHASE PRICE PAID WITHIN A REASONABLE PERIOD OF TIME. IN NO EVENT IS SELLER LIABLE FOR ANY SPECIAL, INDIRECT, INCIDENTAL OR CONSEQUENTIAL DAMAGES INCLUDING ANY LOSS OF REVENUE OR PROFITS, WHETHER BASED IN CONTRACT, TORT OR OTHER LEGAL THEORY. IN NO EVENT SHALL SELLER'S LIABILITY UNDER ANY CLAIM MADE BY BUYER EXCEED THE PURCHASE PRICE PAID FOR THE PRODUCTS.

8. Confidential Information. Buyer acknowledges and agrees that Confidential Information has been and will be received in confidence and will remain the property of Seller. Buyer further agrees that it will not use Seller's Confidential Information for any purpose other than for the benefit of Seller and shall return all such Confidential Information to Seller within thirty (30) days upon request.

9. Loss to Buyer's Property. Buyer's Property will be considered obsolete and may be destroyed by Seller after two (2) consecutive years have elapsed without Buyer ordering the Products manufactured using Buyer's Property.

Also, Seller shall not be responsible for any loss or damage to Buyer's Property while it is in Seller's possession or control.

10. Special Tooling. Seller may impose a tooling charge for any Special Tooling. Special Tooling shall be and remain Seller's property. In no event will Buyer acquire any interest in the Special Tooling, even if such Special Tooling has been specially converted or adapted for manufacture of Goods for Buyer and notwithstanding any charges paid by Buyer. Unless otherwise agreed, Seller has the right to alter, discard or otherwise dispose of any Special Tooling or other property owned by Seller in its sole determination at any time.

11. Security Interest. To secure payment of all sums due from Buyer, Seller retains a security interest in all Products delivered to Buyer and, Buyer's acceptance of these Terms is deemed to be a Security Agreement under the Uniform Commercial Code. Buyer authorizes Seller as its attorney to execute and file on Buyer's behalf all documents Seller deems necessary to perfect Seller's security interest.

12. User Responsibility. Buyer, through its own analysis and testing, is solely responsible for making the final selection of the Products and assuring that all performance, endurance, maintenance, safety and warning requirements of the application of the Products are met. Buyer must analyze all aspects of the application and follow applicable industry standards, specifications, and any technical information provided with the Quote or the Products, such as Seller's instructions, guides and specifications. If Seller provides options of or for Products based upon data or specifications provided by Buyer, Buyer is responsible for determining that such data and specifications are suitable and sufficient for all applications and reasonably foreseeable uses of the Products. In the event Buyer is not the end-user of the Products, Buyer will ensure such end-user complies with this paragraph.

13. Use of Products, Indemnity by Buyer. Buyer shall comply with all instructions, guides and specifications provided by Seller with the Quote or the Products. If Buyer uses or resells the Products in any way prohibited by Seller's instructions, guides or specifications, or Buyer otherwise fails to comply with Seller's instructions, guides and specifications, Buyer acknowledges that any such use, resale, or non-compliance is at Buyer's sole risk. Further, Buyer shall indemnify, defend, and hold Seller harmless from any losses, claims, liabilities, damages, lawsuits, judgments and costs (including attorney fees and defense costs), whether for personal injury, property damage, intellectual property infringement or any other claim, arising out of or in connection with: (a) improper selection, design, specification, application, or any misuse of Products; (b) any act or omission, negligent or otherwise, of Buyer; (c) Seller's use of Buyer's Property; (d) damage to the Products from an external cause, repair or attempted repair by anyone other than Seller, failure to follow instructions, guides and specifications provided by Seller, use with goods not provided by Seller, or opening, modifying, deconstructing, tampering with or repackaging the Products; or (e) Buyer's failure to comply with these Terms, including any legal or administrative proceedings, collection efforts, or other actions arising from or relating to such failure to comply. Seller shall not indemnify Buyer under any circumstance except as otherwise provided in these Terms.

14. Cancellations and Changes. Buyer may not cancel or modify, including but not limited to movement of delivery dates for the Products, any order for any reason except with Seller's written consent and upon terms that will indemnify, defend and hold Seller harmless against all direct, incidental and consequential loss or damage and any additional expense. Seller, at any time, may change features, specifications, designs and availability of Products.

15. Assignment. Buyer may not assign its rights or obligations without the prior written consent of Seller.

16. Force Majeure. Seller is not liable for delay or failure to perform any of its obligations by reason of any events or circumstances beyond its reasonable control. Such circumstances include without limitation: accidents, labor disputes or stoppages, government acts or orders, acts of nature, pandemics, epidemics, other widespread illness, or public health emergency, cyber related disruptions, cyber-attacks, ransomware sabotage, delays or failures in delivery from carriers or suppliers, shortages of materials, sudden increases in the price of raw material or components, shutdowns or slowdowns affecting the supply of raw materials or components, or the transportation thereof, oil shortages or oil price increases, energy crisis, energy or fuel interruption, war (whether declared or not) or the serious threat of same, riots, rebellions, acts of terrorism, embargoes, fire or any reason whether similar to the foregoing or otherwise. Seller will resume performance as soon as practicable after the event of force majeure has been removed. All delivery dates affected by an event of force majeure shall be tolled for the duration of such event of force majeure and rescheduled for mutually agreed dates as soon as practicable after the event of force majeure ceases to exist. The right to allocate capacity is in the Seller's sole discretion. An event of force majeure shall not include

financial distress, insolvency, bankruptcy, or other similar conditions affecting one of the parties, affiliates and/or subcontractors. An event of force majeure in the meaning of these Terms means any circumstances beyond Seller's control that permanently or temporarily hinders performance, even where that circumstance was already foreseen. Buyer shall not be entitled to cancel any orders following its claim of an event of force majeure.

17. Waiver and Severability. Failure to enforce any provision of these Terms will not invalidate that provision; nor will any such failure prejudice either party's right to enforce that provision in the future. Invalidation of any provision of these Terms shall not invalidate any other provision herein and, the remaining provisions will remain in full force and effect.

18. Duration. Unless otherwise stated in the Quote, any agreement governed by or arising from these Terms shall: (a) be for an initial duration of one (1) year; and (b) shall automatically renew for successive one-year terms unless terminated by Buyer with at least 180-days written notice to Seller or if Seller terminates the agreement pursuant to Section 19 of these Terms.

19. Termination. Seller may, without liability to Buyer, terminate any agreement governed by or arising from these Terms for any reason and at any time by giving Buyer thirty (30) days prior written notice. Seller may immediately terminate, in writing, if Buyer: (a) breaches any provision of these Terms, (b) becomes or is deemed insolvent, (c) appoints or has appointed a trustee, receiver or custodian for all or any part of Buyer's property, (d) files a petition for relief in bankruptcy on its own behalf, or one is filed against Buyer by a third party, (e) makes an assignment for the benefit of creditors; or (f) dissolves its business or liquidates all or a majority of its assets.

20. Ownership of Rights. Buyer agrees that (a) Seller (and/or its affiliates) owns or is the valid licensee of Seller's IP and (b) the furnishing of information, related documents or other materials by Seller to Buyer does not grant or transfer any ownership interest or license in or to Seller's IP to Buyer, unless expressly agreed in writing. Without limiting the foregoing, Seller retains ownership of all Software supplied to Buyer. In no event shall Buyer obtain any greater right in and to the Software than a right in a license limited to the use thereof and subject to compliance with any other terms provided with the Software. Buyer further agrees that it will not, directly or through intermediaries, reverse engineer, decompile, or disassemble any Software (including firmware) comprising or contained within a Product, except and only to the extent that such activity may be expressly permitted, either by applicable law or, in the case of open source software, the applicable open source license.

21. Indemnity for Infringement of Intellectual Property Rights. Seller is not liable for infringement of any Intellectual Property Rights except as provided in this Section. Seller will defend at its expense and will pay the cost of any settlement or damages awarded in an action brought against Buyer based on a third-party claim that one or more of the Products infringes the Intellectual Property Rights of a third party in the country of delivery of the Products by Seller to Buyer. Seller's obligation to defend and indemnify Buyer is contingent on Buyer notifying Seller within ten (10) days after Buyer becomes aware of any such claim, and Seller having sole control over the defense of the claim including all negotiations for settlement or compromise. If one or more Products is subject to such a claim, Seller may, at its sole expense and option, procure for Buyer the right to continue using the Products, replace or modify the Products to render them non-infringing, or offer to accept return of the Products and refund the purchase price less a reasonable allowance for depreciation. Seller has no obligation or liability for any claim of infringement: (i) arising from information provided by Buyer (including Seller's use of Buyer's Property); or (ii) directed to any Products for which the designs are specified in whole or part by Buyer; or (iii) resulting from the modification, combination or use in a system of any Products. The foregoing provisions of this Section constitute Seller's sole and exclusive liability and Buyer's sole and exclusive remedy for claims of infringement of Intellectual Property Rights.

22. Governing Law. These Terms, the terms of any Quote, and the sale and delivery of all Products are deemed to have taken place in, and shall be governed and construed in accordance with, the laws of the State of Ohio, as applicable to contracts executed and wholly performed therein and without regard to conflicts of laws principles. Buyer irrevocably agrees and consents to the exclusive jurisdiction and venue of the courts of Cuyahoga County, Ohio with respect to any dispute, controversy or claim arising out of or relating to the sale and delivery of the Products.

23. Entire Agreement. These Terms, along with the terms set forth in the Quote, forms the entire agreement between the Buyer and Seller and constitutes the final, complete and exclusive expression of the terms of sale and purchase. In the event of a conflict between any term set forth in the Quote and these Terms, the terms set forth in the Quote shall prevail. All prior or contemporaneous written or oral agreements or negotiations with

respect to the subject matter shall have no effect. No modification to these Terms will be binding on Seller unless agreed to in a writing that is signed by an authorized representative of Seller, excluding email correspondence, 'clickwrap' or other purported electronic assent to different or additional terms. Sections 2-25 of these Terms shall survive termination or cancellation of any agreement governed by or arising from these Terms.

24. No 'Wrap' Agreements/No Authority to Bind. Seller's clicking any buttons or any similar action, such as clicking "I Agree" or "Confirm," to utilize Buyer's software or webpage for the placement of orders, is NOT an agreement to Buyer's Terms and Conditions. **NO EMPLOYEE, AGENT OR REPRESENTATIVE OF SELLER HAS THE AUTHORITY TO BIND SELLER BY THE ACT OF CLICKING ANY BUTTON OR SIMILAR ACTION ON BUYER'S WEBSITE OR PORTAL.**

25. Compliance with Laws. Buyer agrees to comply with all applicable laws, regulations, and industry and professional standards, including those of the United States of America, and the country or countries in which Buyer may operate, including without limitation the U.S. Foreign Corrupt Practices Act ("FCPA"), the U.S. Anti-Kickback Act ("Anti-Kickback Act"), U.S. and E.U. export control and sanctions laws ("Export Laws"), the U.S. Food Drug and Cosmetic Act ("FDCA"), and the rules and regulations promulgated by the U.S. Food and Drug Administration ("FDA"), each as currently amended. Buyer agrees to indemnify, defend, and hold harmless Seller from the consequences of any violation of such laws, regulations and standards by Buyer, its employees or agents. Buyer represents that it is familiar with all applicable provisions of the FCPA, the Anti-Kickback Act, Export Laws, the FDCA and the FDA and certifies that Buyer will adhere to the requirements thereof and not take any action that would make Seller violate such requirements. Buyer represents and agrees that Buyer will not make any payment or give anything of value, directly or indirectly, to any governmental official, foreign political party or official thereof, candidate for foreign political office, or commercial entity or person, for any improper purpose, including the purpose of influencing such person to purchase Products or otherwise benefit the business of Seller. Buyer further represents and agrees that it will not receive, use, service, transfer or ship any Products from Seller in a manner or for a purpose that violates Export Laws or would cause Seller to be in violation of Export Laws. Buyer agrees to promptly and reliably provide Seller all requested information or documents, including end-user statements and other written assurances, concerning Buyer's ongoing compliance with Export Law.



Parker Hannifin Corporation
Pump & Motor Division
101 Canterbury Road
Kings Mountain, NC 28086
Phone: (704) 730-2000
Fax: (704) 730-7411
www.parker.com/gearpump
www.phtruck.com

Your Local Authorized Parker Distributor